

PART III: CONSUMER INFORMATION

LUVERIS[®]

lyophilized powder for reconstitution

This leaflet is part III of a three-part "Product Monograph" published when LUVERIS was approved for sale in Canada and is designed specifically for Consumers. This leaflet is a summary and will not tell you everything about LUVERIS. Contact your doctor or pharmacist if you have any questions about the drug.

ABOUT THIS MEDICATION

What the medication is used for:

- Biologic medication used to treat hypogonadotropic hypogonadism in women
- Purified hormone that should be taken under close supervision of the doctor who prescribed it

What it does:

Women with hypogonadotropic hypogonadism have pituitary glands that do not release follicle stimulating hormone (FSH) or luteinizing hormone (LH). This means that the follicles are unable to develop and mature, so ovulation cannot take place.

LUVERIS (lutropin alpha for injection) provides you with LH that may be necessary to be given along with GONAL-F (follitropin alpha for injection) that provides you with FSH. FSH is necessary for the recruitment, growth, and maturation of the ovarian follicles which contain eggs known as ova or oocytes. The addition of LUVERIS to GONAL-F may enhance this process. This occurs during the first half of the female reproductive cycle. After LUVERIS and GONAL-F are given to help develop ovarian follicles, another hormone, hCG (human chorionic gonadotropin), may be given mid-cycle to mature the eggs and cause ovulation.

When it should not be used:

- If you are allergic (hypersensitive) to gonadotrophins (such as luteinizing hormone, follicle stimulating hormone or human chorionic gonadotropin), or any of the other ingredients of LUVERIS.
- If you have been diagnosed as having ovarian, uterine or breast cancer.
- If you have had a brain tumour diagnosed.
- If you have ovarian enlargement or ovarian cyst unrelated to polycystic ovarian disease and of unknown origin.
- If you have unexplained vaginal bleeding.

The medicine must not be used when a condition exists which would make a normal pregnancy impossible, such as:

- Premature menopause
- Malformation of sexual organs
- Specific tumours of the womb

What the medicinal ingredient is:

It is called lutropin alpha, and is a protein naturally found in the

body. Through recombinant DNA (rDNA) technology the products manufactured are composed of highly purified hormones that offer a consistent dosage and do not contain urinary proteins.

What the important nonmedicinal ingredients are:

Sucrose, L-methionine, disodium phosphate dihydrate, sodium dihydrogen phosphate monohydrate, and Polysorbate 20.

What dosage forms it comes in:

Dry powder for reconstitution. A solution is prepared (75 IU LUVERIS with 1 mL Sterile Water for Injection) and then injected subcutaneously.

WARNINGS AND PRECAUTIONS

BEFORE you use LUVERIS talk to your doctor or pharmacist if:

- You have sex hormone-dependent tumours of the reproductive tract and accessory organs
- You have active, untreated tumours of the hypothalamus or pituitary gland
- You are pregnant or are breast-feeding your baby
- You have ovarian failure
- You have abnormal uterine bleeding of unknown origin
- You have hypersensitivity to gonadotropins or to any of the non-medicinal ingredients

Compared with natural conception, the incidence of multiple pregnancies (mainly twins) and births is increased in patients undergoing this type of treatment. However, this can be minimized by using the recommended dose and schedule of administration.

Miscarriages are higher than in the normal population, but comparable with the rates found in women with fertility problems.

Women with a history of tubal disease are at a risk of ectopic pregnancy (pregnancy where the embryo is implanted outside the womb), whether the pregnancy is obtained by spontaneous conception or with fertility treatments.

There have been reports of tumours of the ovary and other reproductive organs, both benign and malignant, in women who have undergone multiple drug regimens for infertility treatment.

If you are at risk of thromboembolic events (formation of a blood clot in vein or artery), because of your personal or family history, treatment with gonadotropins, like pregnancy itself, may further increase the risk. If you think you may have such a risk, please ask your doctor.

Birth defects after ART (Assisted Reproduction Techniques) may be slightly higher than after spontaneous conceptions,

although this is not confirmed. This could be due to differences in parental factors like maternal age, genetics, as well as the ART procedures and multiple pregnancies.

INTERACTIONS WITH THIS MEDICATION

Please tell your doctor or pharmacist if you are taking or have recently taken any other medicines, including medicines obtained without a prescription.

LUVERIS has not been shown to affect the activity of co-administered GONAL-F.

PROPER USE OF THIS MEDICATION

Usual dose:

LUVERIS is usually taken every day for up to three weeks simultaneously with injections of FSH. The usual dose starts with 75 IU of LUVERIS together with 75 IU or 150 IU of FSH. According to your response, your doctor may increase your dose of FSH by preferably 37.5-75 IU at 7-14 day intervals. Your physician may decide to extend your treatment up to 5 weeks.

Overdose:

The effects of an overdose of LUVERIS are unknown, nevertheless there is a possibility that ovarian hyperstimulation syndrome may occur. If you inject more medication at one time that you were prescribed, you should contact your doctor.

In case of drug overdose, contact a health care practitioner, hospital emergency department or regional Poison Control Centre immediately, even if there are no symptoms.

Missed Dose:

If you forget to take LUVERIS, do not take a double dose. In the case of a forgotten dose, please contact your doctor.

SIDE EFFECTS AND WHAT TO DO ABOUT THEM

As with any drug, you may experience side effects when taking LUVERIS. In clinical trials, the most common side effects (experienced by more than 2% of patients) were headache, pelvic and abdominal pain, nausea, OHSS, breast pain, ovarian cysts, flatulence, injection site reactions, general pain, constipation, fatigue, painful menstruation, ovarian disorder, diarrhea and upper respiratory tract infections.

When taking LUVERIS, there is a risk of developing ovarian hyperstimulation syndrome (OHSS). The early warning signs of development of OHSS are severe abdominal pain, nausea, vomiting and weight gain. Since OHSS develops rapidly, if you experience any of these symptoms, contact your doctor immediately.

It is important to regularly tell your health care professional

how you are feeling and if you have developed any new symptoms while taking LUVERIS.

SERIOUS SIDE EFFECTS, HOW OFTEN THEY HAPPEN AND WHAT TO DO ABOUT THEM

The most serious side effect associated with LUVERIS is ovarian hyperstimulation syndrome (OHSS). If you experience the early warning signs of OHSS, including severe abdominal pain, nausea, vomiting and weight gain, contact your doctor as soon as possible.

This is not a complete list of side effects. For any unexpected effects while taking LUVERIS, contact your doctor or pharmacist.

HOW TO STORE IT

Lyophilized vials are stable when stored at 2-25°C and protected from light. Do not expose to extreme heat or cold. Do not use the product after the expiry date indicated on the label.

Do not use LUVERIS if you notice any signs of deterioration or damage to the container. The solution should not be administered if it contains particles or is not clear.

How to prepare and inject a dose of LUVERIS

Before you start, clean your work surface. Wash your hands well with soap and water.

It is important that your hands and the items you use be as clean as possible. Needles should not touch any surface except inside the LUVERIS vial and your skin that has been cleaned with alcohol. Keep needles capped prior to use. Make sure you use a new needle each time you inject to avoid contamination. Dispose of all used needles and glass in the disposal container provided.

Assemble everything you need:

- Two alcohol swabs
- One vial of diluent
- One vial of LUVERIS
- One syringe
- One needle for mixing (long)
- One fine-bore needle for subcutaneous injection (short)

If you use your kitchen to prepare the injection, ensure that all medicines and needles are kept well away from food. As for the injection itself, it can be given in any room where you feel comfortable.

Opening and drawing up the diluent

Opening the vial(s) of diluent:

You should have one vial containing diluent (clear liquid) and one vial containing LUVERIS (white powder) as prescribed by your doctor.

- Remove the protective cap from the vial containing the

diluent.

- Use an alcohol swab to cleanse the metal ring and rubber stopper.
- Discard the alcohol swab.

Drawing up the diluent from the vial:

- Remove the syringe from its package and carefully uncover the needle, taking care not to let the needle touch any surface.
- Pull the plunger back until it is at the line next to the number showing the amount of diluent that you need to draw up (example 1 cc).
- Place the vial on a clean, flat surface. Push the needle through the centre of the rubber stopper on the vial. Then, push the plunger all the way in.
- Keeping the needle in the vial, lift the vial and turn it upside down. Check to see that the needle tip is in the liquid. Be sure you completely cover the needle tip with liquid before pulling back on the plunger.
- Slowly pull the plunger back until you see the required amount of diluent in the syringe. Discard the vial containing any unused diluent into the disposal container.
- Carefully replace the cap on the needle and place the syringe on a clean surface.

Preparing the injection solution

- Remove the protective cap from the LUVERIS powder vial. Use an alcohol swab to cleanse the metal ring and rubber stopper. Discard the alcohol swab.
- Pick up the syringe containing the diluent and carefully remove the cap.
- Slowly inject the required amount of diluent into the powder vial.
- Leaving the needle in the vial, gently rotate the vial between your fingers until all of the powder is dissolved. Do not shake. Check that the solution is clear and colorless. Do not use if the solution is cloudy, discolored, or contains particles.

Drawing up the solution

- After the powder has dissolved, turn the vial upside down, and gently draw up the entire contents of the vial into the syringe, being careful not to pull the plunger out of the syringe. It may help to slowly tip the vial.
- You may also mix LUVERIS and GONAL-F (follitropin alpha for injection) together as an alternative to injecting each product separately. Add the GONAL-F solution into the vial of LUVERIS.

Changing the needle

- Hold the syringe with the needle pointing upwards. Create an airspace at the top of the barrel by gently pulling the plunger back. Carefully recap the needle, then twist and remove it.
- Replace the long mixing needle with the fine-bore short

needle for injection. Hold the syringe with the needle pointing upwards and gently flick the syringe if there are any visible air bubbles. Gently push the plunger until all the air bubbles are gone.

- Do not worry if you are unable to remove very tiny bubbles. Gently push the plunger upwards until a small droplet of liquid appears at the tip of the needle.
- Replace the cap on the needle and place the syringe on a clean surface.

Preparing the injection site

- Select the site of injection (e.g. top of thigh, tummy). Refer to the injection site diagram provided to you by your physician in the “Patient Instructions for LUVERIS”. Choose a different site each day.
- Wipe the chosen area with an alcohol swab, cleansing an area of approximately 5 cm x 5 cm (an area about the size of a square tea bag).
- Lay the used side of the swab next to your working surface or on the alcohol swab wrapper.

Injecting the solution

- Pick up the syringe and remove the cap from the needle. Invert the needle and using the hand with which you write, hold the syringe like a pencil or as if “throwing a dart”. With your other hand, gently squeeze the skin together to make a little elevation at the injection site.
- Using a “dart like motion”, insert the needle at a 90° angle. (You need very little force but quick action).
- Inject the solution by gently pushing on the plunger with your index finger. Take as much time as you need to inject all the solution. As you release the skin from your grip, withdraw the needle by pulling it straight out.
- Clean the skin with the clean side of the alcohol swab using a circular motion. If there is minor oozing you may need to apply a small amount of pressure.

Disposal

Once you have finished your injection, immediately discard the needles and syringe (without recapping the needle) into the disposal container.

REPORTING SUSPECTED SIDE EFFECTS

You can report any suspected adverse reactions associated with the use of health products to the Canada Vigilance Program by one of the following 3 ways:

- **Report online at www.healthcanada.gc.ca/medeffect**
- **Call toll-free at 1-866-234-2345**
- **Complete a Canada Vigilance Reporting Form and:**
 - **Fax toll-free to 1-866-678-6789, or**
 - **Mail to: Canada Vigilance Program**
Health Canada
Postal Locator 0701E
Ottawa, Ontario
K1A 0K9

Postage paid labels, Canada Vigilance Reporting Form and the adverse reaction reporting guidelines are available on the MedEffect™ Canada Web site at www.healthcanada.gc.ca/medeffect.

NOTE: Should you require information related to the management of side effects, contact your health professional. The Canada Vigilance Program does not provide medical advice.

MORE INFORMATION

This document plus the full product monograph, prepared for health professionals can be found at: <http://www.emdserono.ca> or by contacting the sponsor, EMD Serono, A Division of EMD Inc, Canada at: 1-888-737-6668.

This leaflet was prepared by EMD Serono, A Division of EMD Inc., Canada.

Last revised: February 2012

PART III: CONSUMER INFORMATION

LUVERIS[®]

Solution for Injection in a pre-filled Pen

This leaflet is part III of a three-part "Product Monograph" published when LUVERIS was approved for sale in Canada and is designed specifically for Consumers. This leaflet is a summary and will not tell you everything about LUVERIS. Contact your doctor or pharmacist if you have any questions about the drug.

ABOUT THIS MEDICATION

What the medication is used for:

- Biologic medication used to treat hypogonadotropic hypogonadism in women
- Purified hormone that should be taken under close supervision of the doctor who prescribed it

What it does:

Women with hypogonadotropic hypogonadism have pituitary glands that do not release follicle stimulating hormone (FSH) or luteinizing hormone (LH). This means that the follicles are unable to develop and mature, so ovulation cannot take place.

LUVERIS (lutropin alpha for injection) provides you with LH that may be necessary to be given along with GONAL-F (follitropin alpha for injection) that provides you with FSH. FSH is necessary for the recruitment, growth, and maturation of the ovarian follicles which contain eggs known as ova or oocytes. The addition of LUVERIS to GONAL-F may enhance this process. This occurs during the first half of the female reproductive cycle. After LUVERIS and GONAL-F are given to help develop ovarian follicles, another hormone, hCG (human chorionic gonadotropin), may be given mid-cycle to mature the eggs and cause ovulation.

When it should not be used:

- If you are allergic (hypersensitive) to gonadotrophins (such as luteinizing hormone, follicle stimulating hormone or human chorionic gonadotropin), or any of the other ingredients of LUVERIS.
- If you have been diagnosed as having ovarian, uterine or breast cancer.
- If you have had a brain tumour diagnosed.
- If you have ovarian enlargement or ovarian cyst unrelated to polycystic ovarian disease and of unknown origin.
- If you have unexplained vaginal bleeding.
-

The medicine must not be used when a condition exists which would make a normal pregnancy impossible, such as:

- Premature menopause
- Malformation of sexual organs
- Specific tumours of the womb

What the medicinal ingredient is:

It is called lutropin alpha, and is a protein naturally found in the

body. Through recombinant DNA (rDNA) technology the products manufactured are composed of highly purified hormones that offer a consistent dosage and do not contain urinary proteins.

What the important nonmedicinal ingredients are:

L-arginine HCl, disodium phosphate dihydrate, sodium dihydrogen phosphate monohydrate, Polysorbate 20, L-methionine, and phenol.

What dosage forms it comes in:

LUVERIS is presented as a clear, colourless solution for injection in a pre-filled pen. It is supplied in a pre-filled pen containing 450 IU in 0.72mL which allows for delivery of 6 doses of 75 IU.

WARNINGS AND PRECAUTIONS

BEFORE you use LUVERIS talk to your doctor or pharmacist if:

- You have sex hormone-dependent tumours of the reproductive tract and accessory organs
- You have active, untreated tumours of the hypothalamus or pituitary gland
- You are pregnant or are breast-feeding your baby
- You have ovarian failure
- You have abnormal uterine bleeding of unknown origin
- You have hypersensitivity to gonadotropins or to any of the non-medicinal ingredients

Compared with natural conception, the incidence of multiple pregnancies (mainly twins) and births is increased in patients undergoing this type of treatment. However, this can be minimized by using the recommended dose and schedule of administration.

Miscarriages are higher than in the normal population, but comparable with the rates found in women with fertility problems.

Women with a history of tubal disease are at a risk of ectopic pregnancy (pregnancy where the embryo is implanted outside the womb), whether the pregnancy is obtained by spontaneous conception or with fertility treatments.

There have been reports of tumours of the ovary and other reproductive organs, both benign and malignant, in women who have undergone multiple drug regimens for infertility treatment.

If you are at risk of thromboembolic events (formation of a blood clot in vein or artery), because of your personal or family history, treatment with gonadotropins, like pregnancy itself, may further increase the risk. If you think you may have such a risk, please ask your doctor.

Birth defects after ART (Assisted Reproduction Techniques)

may be slightly higher than after spontaneous conceptions, although this is not confirmed. This could be due to differences in parental factors like maternal age, genetics, as well as the ART procedures and multiple pregnancies.

INTERACTIONS WITH THIS MEDICATION

Please tell your doctor or pharmacist if you are taking or have recently taken any other medicines, including medicines obtained without a prescription.

LUVERIS has not been shown to affect the activity of co-administered GONAL-F.

PROPER USE OF THIS MEDICATION

Usual dose:

LUVERIS is usually taken every day for up to three weeks simultaneously with injections of FSH. The usual dose starts with 75 IU of LUVERIS together with 75 IU or 150 IU of FSH. According to your response, your doctor may increase your dose of FSH by preferably 37.5-75 IU at 7-14 day intervals. Your physician may decide to extend your treatment up to 5 weeks.

Overdose:

The effects of an overdose of LUVERIS are unknown, nevertheless there is a possibility that ovarian hyperstimulation syndrome may occur. If you inject more medication at one time that you were prescribed, you should contact your doctor.

In case of drug overdose, contact a health care practitioner, hospital emergency department or regional Poison Control Centre immediately, even if there are no symptoms.

Missed Dose:

If you forget to take LUVERIS, do not take a double dose. In the case of a forgotten dose, please contact your doctor.

SIDE EFFECTS AND WHAT TO DO ABOUT THEM

As with any drug, you may experience side effects when taking LUVERIS. In clinical trials, the most common side effects (experienced by more than 2% of patients) were headache, pelvic and abdominal pain, nausea, OHSS, breast pain, ovarian cysts, flatulence, injection site reactions, general pain, constipation, fatigue, painful menstruation, ovarian disorder, diarrhea and upper respiratory tract infections.

When taking LUVERIS, there is a risk of developing ovarian hyperstimulation syndrome (OHSS). The early warning signs of development of OHSS are severe abdominal pain, nausea, vomiting and weight gain. Since OHSS develops rapidly, if you experience any of these symptoms, contact your doctor immediately.

SERIOUS SIDE EFFECTS, HOW OFTEN THEY HAPPEN AND WHAT TO DO ABOUT THEM

The most serious side effect associated with LUVERIS is ovarian hyperstimulation syndrome (OHSS). If you experience the early warning signs of OHSS, including severe abdominal pain, nausea, vomiting and weight gain, contact your doctor as soon as possible.

This is not a complete list of side effects. If you experience any unusual symptoms or side effects, you should report them to your doctor immediately.

How is LUVERIS administered?

LUVERIS is intended for subcutaneous use which means it is given by injection under the skin. With professional guidance, you can learn to do your own injections in the comfort and privacy of your own home.

Why is LUVERIS provided in the pre-filled Pen?

LUVERIS is provided in the pre-filled pen to help you easily self-administer accurate and consistent LUVERIS. It is designed so that the dosage is easy to read. The pen reservoir is clear so that the amount of medication available in the Pen can be seen at all times.

Understandably, you may be a little anxious at first about giving yourself an injection. That is why this information has been produced. Refer to it as necessary and follow each instruction step by step.

Always take LUVERIS exactly as your doctor has instructed you. You should check with your health care provider if you are unsure. Before starting to use your pen, please read these instructions the whole way through first. This pen has been prescribed for you – do not let anyone else use it. The numbers on the dose display are measured in International Units or IU. Your doctor would have told you how many IUs to inject each day. Give yourself the injection at the same time each day.

Where should I inject LUVERIS?

The most easily accessible areas for subcutaneous injection are the abdomen and thighs. The absorption of LUVERIS is the same regardless of the injection site selected. You may find the injection is more comfortable if you vary the site each time you inject LUVERIS.



LUVERIS prefilled Pen:

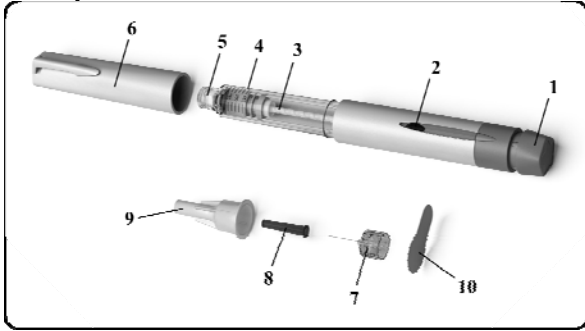

1. Dose setting knob
2. Dose display
3. Plunger piston
4. Reservoir holder
5. Threaded needle connector
6. Pen cap
7. Removable needle
8. Inner needle shield
9. Outer needle cap
10. Peel tab

Please note: The reservoir holder will give you an indication of how much medication you have left. Do not use it to set the dose.

Getting Ready

- Wash your hands with soap and water. It is important that your hands and the items you use be as clean as possible.
- On a clean work surface, e.g. clean table or kitchen surface, lay out everything you will need: LUVERIS Pen, one injection needle (1/2 inch 29 gauge), 2 alcohol swabs, needle disposal container.

Preparing LUVERIS Pen for first time use:

- Remove the pen cap and attach a needle as described in Step 1 (How to use the LUVERIS Pen in 3 easy steps).
- Look carefully at the reservoir holder.
- If you don't notice a large air bubble, the pre-filled pen is ready for use. Please go straight to Step 2 "Setting your dose". If you see a large air bubble inside the reservoir you need to remove it. An air bubble is large if it fills fully the tip of the reservoir when holding the pre-filled pen with the needle pointing upwards. **Small air bubbles that stick to the inner wall of the reservoir do not need to be removed. They are not harmful.**



To remove a large air bubble:

- Gently turn the dose setting knob clockwise until it reads 25 IU preceded by a dot (●) in the dose display. If you pass this position, simply turn the dose setting knob back to 25 and dot (●).

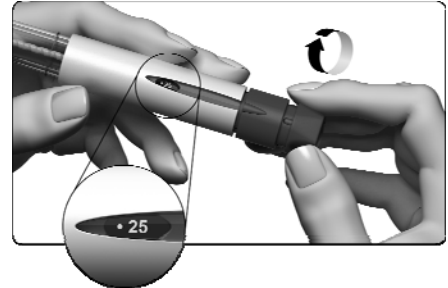

- Carefully remove the outer needle cap and the inner needle shield and hold the pen with the needle pointing upwards. [Do not throw away the outer needle cap; you will need it for removing the needle from the pre-filled pen.]
- Tap the reservoir holder gently with your finger so that any air bubbles rise up towards the needle. With the needle still pointing upwards, press slowly the dose setting knob as far as it will go.
- A drop of liquid must appear at the tip of the needle; this shows that your pre-filled pen is ready for injection. The amount of liquid seen at the needle tip is part of the overfill from the pre-filled pen

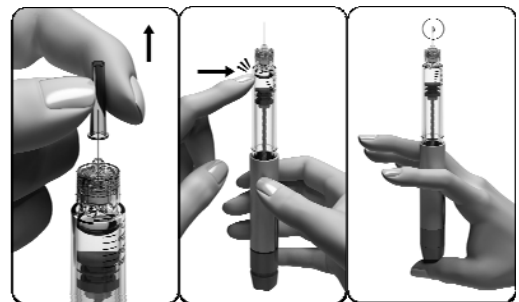

- Now go to Step 2 "Setting your dose" (How to use the LUVERIS Pen in 3 easy Steps).

Note: This step 'Preparing LUVERIS Pen for first time use' does not need to be repeated again while you are using the same pen.

For your next injection, attach a needle and set the dose, as described in Step 1 and 2 (How to use the LUVERIS Pen in 3 easy Steps).

How to use the LUVERIS Pen in 3 easy steps:

Step 1. Uncap pen and put needle on.

- Take the pen cap off. Wipe the end of the threaded tip (containing the rubber center) using an alcohol swab.

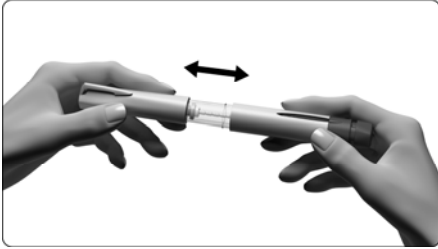

- Take a new needle – only use the “single-use” needles supplied for the LUVERIS pre-filled pen.
- Check that the peel-off seal on the outer needle cap is not damaged or loose. (If it is damaged or loose, do not use the needle and get another one. Throw away the unused needle with the outer needle cap still on. Ask your health care provider how to dispose of needles that are no longer required.)
- Remove the peel tab from the outer needle cap.
- Hold the outer needle cap firmly.
- Press the threaded tip of the pen into the outer needle cap and twist it clockwise. Twist it until it is firmly fixed.

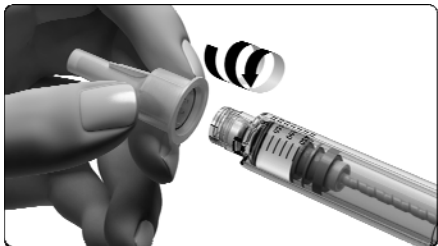

Step 2. Setting your dose

- Gently turn the dose setting knob clockwise until you can read your dose through the dose display. Do not push or pull the dose setting knob while you turn it.

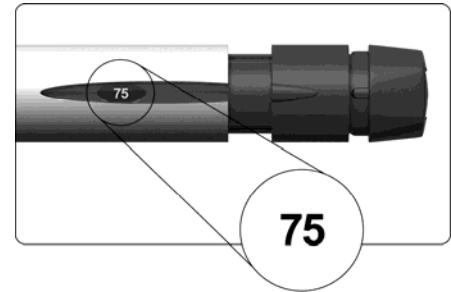
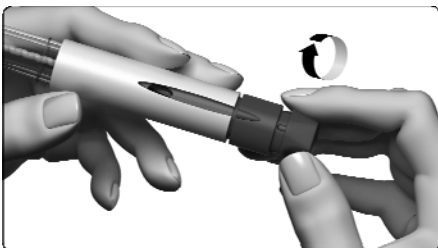

- If you pass your dose simply turn the dose setting knob back to the correct dose. To adjust the dose, you can turn the dose dial either clockwise or counter-clockwise.

Step 3. Injecting your medication.

- Select the site of injection (example: top of thigh or abdomen) making sure to choose a different site each day. Choosing a different injection site each day may minimise skin irritation
- Wipe the chosen area with an alcohol wipe, cleansing an area of about 5 cm x 5 cm. Allow the alcohol to dry. Set the alcohol wipe to the side.
- Check again the dose shown in the dose display. If it is not the correct dose, you must adjust it by turning the dose setting knob either clockwise or counter-clockwise (see step 2 “Setting your dose”).
- If not already done in step “Preparing LUVERIS Pen for first time use”, remove the outer needle cap and the inner needle shield from the needle.
- **Do not throw away the outer needle cap; you will need it for removing the needle from the pre-filled pen.**
- Holding the pen in one hand, use your other hand to gently squeeze the skin together to make a raised area at the injection site.
- Using a ‘dart like motion’, insert the needle at a 90-degree angle into the skin. (You need very little force but quick action.)
- Press the dose setting knob as far as it will go. (You must keep the needle in the skin with the dose setting knob pressed down for at least 10 seconds.)
- The dose number shown in the dose display will turn back to 0. This indicates that the complete dose was delivered.
- After 10 seconds, keep the dose setting knob pressed down, and take the needle out of the skin

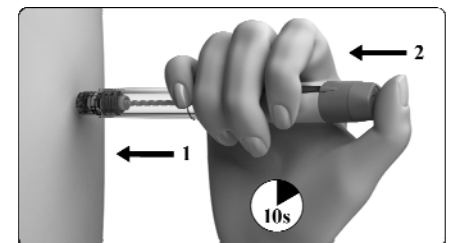

TIP: Keep your thumb on the injection button, while removing the needle from your skin.

- Use the clean side of your alcohol swab to gently clean the injection site. If there is minor oozing you may need to apply a small amount of pressure for a few seconds.

After the injection

1. Making sure you have given a complete injection

- Check that the dose display shows 0. This confirms that the dose has been completed correctly.

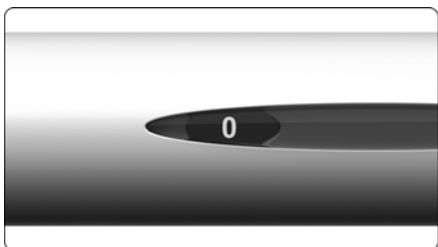

- **CAUTION: If the dose display shows a number higher than 0, this indicates that the pre-filled pen is empty and that the complete dose has not been given.** If this happens, the number shown in the dose display indicates the missing amount of LUVERIS solution that is needed to complete your dose. This is the dose you need to inject using a new pre-filled pen.
- To complete your dose, follow the steps described above from “Before you start using the pre-filled pen” through to step “Preparing LUVERIS Pen for first time use” inclusive. After preparing the pen as described in “Before you start using the pre-filled pen” through to step “Preparing LUVERIS Pen for first time use” above, set the dose to the missing amount displayed on the empty pen that you have just finished and inject this amount.

2. Removing the needle

- Remove the needle after each injection.
 - **Hold the pre-filled pen firmly by the reservoir holder.**
 - **Carefully replace the outer needle cap onto the needle.**

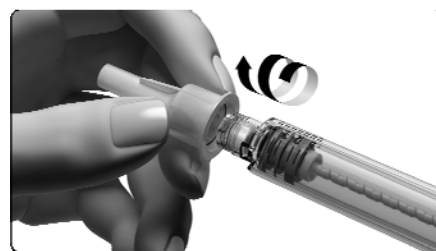
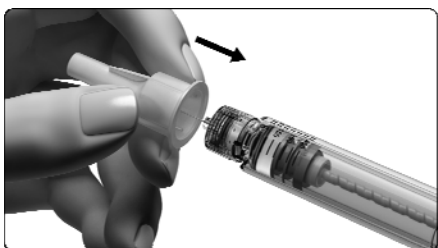

- Grip the outer needle cap and unscrew the needle – do this by turning it counter-clockwise.
- Be careful not to prick yourself with the needle.
- Dispose of the used needle safely into the needle disposal container.
- Put the pen cap back onto the pen.
- Never reuse any needles. Never share needles.

CAUTION: Always remove the needle from the pre-filled pen before putting the pen cap back on. Never store the pen with the needle still attached. The pen cap cannot fit over a pre-filled pen with a needle attached.

3. Storing the pre-filled pen

- Ensure the needle has been removed, as described above.
- Ensure the pen cap is on the pen
- Protect from light (see also “How to store LUVERIS” below).
- Store the pen in a safe place.
- Ask your health care provider on how to dispose of used pens and medicines no longer required.

HOW TO STORE LUVERIS

- Store in a refrigerator (2°C-8°C). Do not freeze. Protect from light. Once, opened, the product must be stored for a maximum of 28 days in a refrigerator (2°C-8°C).
- Do not use LUVERIS if you notice any signs of deterioration or damage to the container. The solution should not be administered if it contains particles or is not clear.
- Do not use the product after the expiry date indicated on the label.
- Keep in a safe place out of the reach of children.

Disposal

Medicines should not be disposed of via wastewater or household waste. Ask your health care provider how to dispose of medicines no longer required.

REPORTING SUSPECTED SIDE EFFECTS

You can report any suspected adverse reactions associated with the use of health products to the Canada Vigilance Program by one of the following 3 ways:

- **Report online at www.healthcanada.gc.ca/medeffect**
- **Call toll-free at 1-866-234-2345**
- **Complete a Canada Vigilance Reporting Form and:**
 - **Fax toll-free to 1-866-678-6789, or**
 - **Mail to: Canada Vigilance Program**
Health Canada
Postal Locator 0701E
Ottawa, Ontario
K1A 0K9

Postage paid labels, Canada Vigilance Reporting Form and the adverse reaction reporting guidelines are available on the MedEffect™ Canada Web site at www.healthcanada.gc.ca/medeffect.

NOTE: Should you require information related to the management of side effects, contact your health professional. The Canada Vigilance Program does not provide medical advice.

MORE INFORMATION

This document plus the full product monograph, prepared for health professionals can be found at: <http://www.emdserono.ca> or by contacting the sponsor, EMD Serono, A Division of EMD Inc., Canada at: 1-888-737-6668.

This leaflet was prepared by EMD Serono, A Division of EMD Inc., Canada.

Last revised: February 2012